

CDMA Cellular Band PA/Duplexer Module

Functional Block Diagram

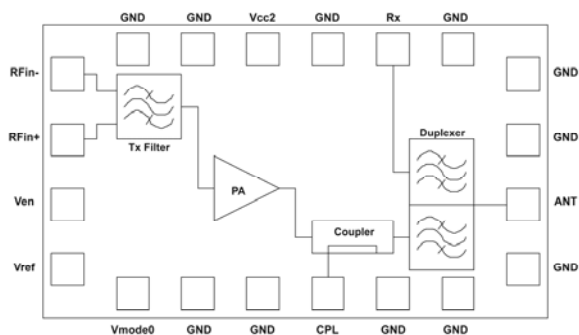

Product Description

TriQuint's TQM613027 is a fully matched CDMA cellular band PA/Duplexer (PAD) module for use in mobile phones. The 7.0 x 4.0 x 1.2 mm, 20-pin module includes a SAW Duplexer, Power Amplifier, Differential input transmit filter, RF Power Coupler and Logic Controller. With an RF Power Output up to 25.5dBm the TQM613027 PAD meets the strict ACPR and ALTR requirements for products designed to the CDMA IS-95/98/2000 standards. It's thin form factor and compact size, coupled with the low quiescent current, makes the TQM613027 ideal for today's compact feature rich multi-media handsets requiring longer battery life.

TriQuint's multilayer laminate technology provides low loss interconnect and optimized match between the duplexer, PA and filter enabling the TQM613027 to achieve only 40 mA of typical current consumption at maximum output power in low power mode (+13.5dBm). The small 7.0 x 4.0 mm module replaces four separate components and matching requiring less board space. TQM613027 provides handset designers with a simple to use surface mount module requiring minimal external circuitry for faster time to market and reduced BOM count.

Electrical Specifications

Test Conditions $V_{CC}=3.4V$, $V_{REF}=2.85V$, $T=+25^{\circ}C$

Parameter	Min	Typ	Max	Units
Frequency	824.7	836.5	848.3	MHz
Pout		+25.5		dBm
ACPR (+/- 885kHz offset)		-50		dBc
ALTR (+/- 1.98 MHz offset)		-60		dBc
Current Consumption @ +25.5 dBm		430		mA
Current Consumption @ +13.5 dBm		40		mA
Quiescent Current		18		mA
Leakage at Rx Port		-31		dBm
ANT-to-Rx Insertion Loss		2.6	3.5	dB
Rx Noise		-182		dBm/Hz

Features

- InGaP GaAs HBT PA with high efficiency at low power architecture
- Low Quiescent Current
Typical: 18 mA
- Low Current Consumption
Typical: 430 mA @ +25.5dBm
Typical: 415 mA @ +24.5dBm
Typical: 40 mA @ +13.5dBm
- Excellent ACPR
Typical: -50 dBc @ +/- 885kHz offset
- Excellent ALTR
Typical: -60 dBc @ +/- 1.98 MHz offset
- Lead-free 260°C RoHS Compliant
- Small 20-pin, 7.0x4.0mm module with matching replacing ~10 discrete components
- Height of 1.17mm for thin phones
- Integrated duplexer, coupler, differential input transmit filter and matching
- Optimized for use with Qualcomm's QSC6010/20/30™ single chip devices

Applications

- IS-95/98/CDMA2000
- Single-band CDMA Cellular radios

Package Style

